

RoHS Compliant

SATA Flash Drive

SFD25H-M Product Specifications

June 11th, 2014

Version 1.2



Apacer Technology Inc.

1F, No.32, Zhongcheng Rd., Tucheng Dist., New Taipei City, Taiwan, R.O.C

Tel: +886-2-2267-8000 Fax: +886-2-2267-2261

www.apacer.com

Features:

- **Serial ATA Revision 3.0 Compliance**
 - SATA 6.0 Gbps interface
 - Backward compatible with SATA 3.0/1.5 Gbps interface
 - ATA Command set
- **Capacities**
 - 512 GB, 1 TB
- **Performance***
 - Burst read/write: 600 MB/sec
 - Sustained read: up to 510 MB/sec
 - Sustained write: up to 420 MB/sec
 - Random Read (4K): 36,000 IOPS
 - Random Write (4K): 22,000 IOPS
- **Flash endurance design**
 - Built-in hardware ECC, enabling up to 72 bit correction per 1K Bytes
 - Wear-leveling
 - Flash bad block management
 - S.M.A.R.T.
 - Power Failure Management
 - TRIM
- **NAND Flash Type:** MLC
- **MTBF (hours):** >1,000,000
- **Temperature ranges**
 - Operating:
 - Standard: 0 °C to 70 °C
 - Extended: -40 °C to 85 °C**
 - Storage: -40 °C to 85 °C
- **Supply voltage**
 - 5 V ± 5%
- **Power consumption (typical)***
 - Active mode: 1,410 mA@5 V
 - Idle mode: 60 mA@5 V
- **Form factor**
 - 2.5 inch
 - Dimensions for 7mm housing: 100.10 x 69.85 x 7.00, unit: mm
 - Dimensions for 9.5mm housing: 100.00 x 69.85 x 9.50, unit: mm
- **Connector**
 - 7-pin SATA male connector
 - 15-pin SATA power connector
- **DDR3 cache for enhanced random performance**
- **RoHS compliant**

*The values presented for Performances and Power Consumption are typical and may vary depending on different configurations and platforms.

**Only available in 512GB model

Table of Contents

1. Product Description	3
1.1 Introduction	3
1.2 Capacity Specification.....	3
1.3 Performance.....	3
1.4 Pin Assignments	4
2. Software Interface	6
2.1 Command Set	6
2.2 S.M.A.R.T.	7
3. Flash Management	8
3.1 Error Correction/Detection.....	8
3.2 Flash Block Management	8
3.3 Wear Leveling.....	8
3.4 Power Failure Management	8
3.5 ATA Secure Erase	8
3.6 TRIM.....	9
4. Reliability Specifications	10
4.1 Environments.....	10
4.2 Mean Time Between Failures (MTBF).....	10
4.3 Certification and Compliance	10
5. Electrical Characteristics	11
5.1 Operating Voltage	11
5.2 Power Consumption.....	11
6. Mechanical Specifications	12
6.1 Dimensions – 7mm Housing	12
6.2 Dimensions – 9.5mm Housing	13
7. Product Ordering Information	14
7.1 Product Code Designations	14
7.2 Valid Combinations.....	15

1. Product Description

1.1 Introduction

Apacer SFD25H-M Embedded Solid State Drive is a speedy and reliable companion for industrial PC and laptops. Designed in SATA 6.0 Gb/s interface, the drive can deliver outstanding performance up to 520 MB/s sustained transfer rate, highly suitable to serve as operating system boot drive or storage media of important data. With its compliance with the latest SATA specification, this cutting edge device supports power management, which greatly saves in power consumption, making it more environmental and economical than traditional hard disk drives.

Regarding data reliability, the controller unit of SFD25H-M is built with a powerful ECC engine in the device correcting up to 72bit per 1KB data. For better I/O performance, the controller unit comes with an external DDR3 cache to strengthen the IOPS (Input Output Per Second) of the device, proving to be the ideal companion for PC and laptop users.

1.2 Capacity Specification

Table 1-1 Capacity specification

Capacity	Total Bytes*	Cylinders	Heads	Sectors	Max LBA**
512 GB	512,110,190,592	16,383	16	63	1,000,215,216
1 TB	1,024,209,543,168	16,383	16	63	2,000,409,264

*Display of total bytes varies from file systems.

**Cylinders, heads or sectors are not applicable for these capacities. Only LBA addressing applies.

***Notes: 1 GB = 1,000,000,000 bytes; 1 sector = 512 bytes.

LBA count addressed in the table above indicates total user storage capacity and will remain the same throughout the lifespan of the device. However, the total usable capacity of the SSD is most likely to be less than the total physical capacity because a small portion of the capacity is reserved for device maintenance usages.

1.3 Performance

Table 1-2 Performance specifications

Performance	Capacity	
	512 GB	1 TB
Sustained Read (MB/s)	510	510
Sustained Write (MB/s)	405	420
Random Read 4K (IOPS)	36,000	27,000
Random Write 4K (IOPS)	22,000	16,000

Note:

1. Results may vary depending on host system configurations.
2. Sustained Read/Write: The read/write performances are measured by CrystalDiskMark under Windows 7 operating system.
3. IOPS was tested on 8GB span (16777216 sectors Disk Size), 32 Outstanding I/Os (QD=32), Full Random Data pattern, 4KB Align I/Os and test time 15min

1.4 Pin Assignments

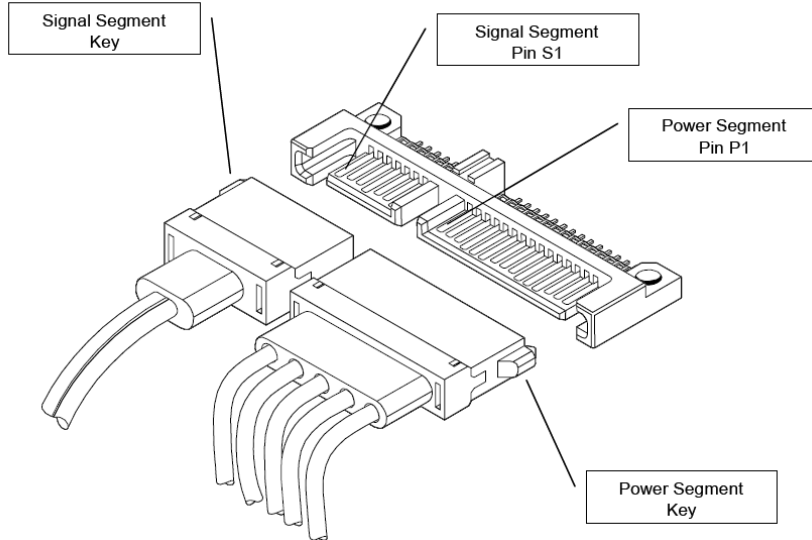

Table 1-4: Signal segment

Pin	Type	Description
S1	GND	
S2	RxP	Serial Data Receiver Signal Pair
S3	RxN	
S4	GND	
S5	TxN	Serial Data Transmitter Signal Pair
S6	TxP	
S7	GND	

Table 1-5: Power segment

Pin	Signal/Description
P1	Not used (3.3V)
P2	Not used (3.3V)
P3	Not used (3.3V)
P4	Ground
P5	Ground
P6	Ground
P7	5V
P8	5V
P9	5V
P10	Ground
P11	Reserved
P12	Ground
P13	Not used (12V)
P14	Not used (12V)
P15	Not used (12V)

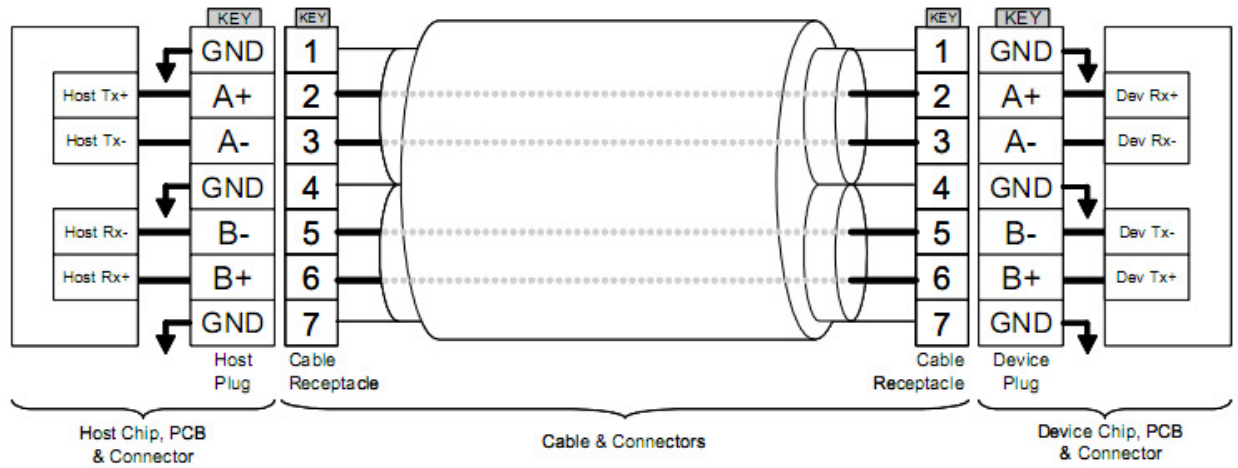

Figure 1-3 SATA Cable / Connector Connection Diagram

The connector on the left represents the Host with TX/RX differential pairs connected to a cable while the connector on the right shows the Device with TX/RX differential pairs also connected to the cable. Notice also the ground path connecting the shielding of the cable to the Cable Receptacle.

2. Software Interface

2.1 Command Set

Command	Code	Command	Code
CHECK Power Mode	E5h	Security Disable Password	F6h
Data Set Management	06h	Security Erase Prepare	F3h
DCO	B1h	Security Erase Unit	F4h
Download Microcode PIO	92h	Security Freeze Lock	F5h
Download Microcode DMA	93h	Security Set Password	F1h
Execute Drive Diagnostic	90h	Security Unlock	F2h
Flush Cache	E7h	Seek	70h
Flush Cache Ext	Eah	Set Features	Efh
Identify Device	Ech	Set Max Address	F9h
Idle	E3h	Set Max Address Ext	37h
Idle Immediate	E1h	Set Multiple Mode	C6h
Initialize Drive Parameters	91h	Sleep	E6h
Read Buffer	E4h	SMART	B0h
Read DMA (W/O retry)	C9h	Standby	E2h
Read DMA (W/ retry)	C8h	Standby Immediate	E0h
Read DMA Ext	25h	Write Buffer	E8h
Read FPDMA Queued	60h	Write DMA (W/O retry)	CBh
Read Log Ext	2Fh	Write DMA (W/ retry)	Cah
Read Multiple	C4h	Write DMA Ext	35h
Read Multiple Ext	29h	Write DMA FUA Ext	3Dh
Read Native Max Address	F8h	Write FPDMA Queued	61h
Read Native Max Ext	27h	Write Log Ext	3Fh
Read Sector(s) (W/O retry)	21h	Write Multiple	C5h
Read Sector(s) (W/ retry)	20h	Write Multiple Ext	39h
Read Sector(s) Ext	24h	Write Multiple FUA Ext	Ceh
Read Verify Ext	42h	Write Sector(s) (W/O retry)	31h
Read Verify Sector(s) (W/O retry)	41h	Write Sector(s) (W/ retry)	30h
Read Verify sector(s) (W/ retry)	40h	Write Sector(s) Ext	34h
Recalibrate	10h	Write Uncorrectable	45h

2.2 S.M.A.R.T.

S.M.A.R.T. is an acronym for Self-Monitoring, Analysis and Reporting Technology, an open standard allowing disk drives to automatically monitor their own health and report potential problems. It protects the user from unscheduled downtime by monitoring and storing critical drive performance and calibration parameters. Ideally, this should allow taking proactive actions to prevent impending drive failure.

3. Flash Management

3.1 Error Correction/Detection

This device implements hardware ECC scheme based on the BCH algorithm which can detect and correct up to 72 bits error in 1K Bytes.

3.2 Flash Block Management

Current production technology is unable to guarantee total reliability of NAND flash memory array. When a flash memory device leaves factory, it comes with a minimal number of initial bad blocks during production or out-of-factory as there is no currently known technology that produce flash chips free of bad blocks. In addition, bad blocks may develop during program/erase cycles. When host performs program/erase command on a block, bad block may appear in Status Register. Since bad blocks are inevitable, the solution is to keep them in control. Apacer flash devices are programmed with ECC, block mapping technique and S.M.A.R.T to reduce invalidity or error. Once bad blocks are detected, data in those blocks will be transferred to free blocks and error will be corrected by designated algorithms.

3.3 Wear Leveling

Flash memory devices differ from Hard Disk Drives (HDDs) in terms of how blocks are utilized. For HDDs, when a change is made to stored data, like erase or update, the controller mechanism on HDDs will perform overwrites on blocks. Unlike HDDs, flash blocks cannot be overwritten and each P/E cycle wears down the lifespan of blocks gradually. Repeatedly program/erase cycles performed on the same memory cells will eventually cause some blocks to age faster than others. This would bring flash storages to their end of service term sooner. Wear leveling is an important mechanism that level out the wearing of blocks so that the wearing-down of blocks can be almost evenly distributed. This will increase the lifespan of SSDs. Commonly used wear leveling types are Static and Dynamic.

3.4 Power Failure Management

Power Failure Management plays a crucial role when experiencing unstable power supply. Power disruption may occur when users are storing data into the SSD. In this urgent situation, the controller would run multiple write-to-flash cycles to store the metadata for later block rebuilding. This urgent operation requires about several milliseconds to get it done. At the next power up, the firmware will perform a status tracking to retrieve the mapping table and resume previously programmed NAND blocks to check if there is any incompleteness of transmission.

Note: The controller unit of this product model is designed with a DRAM as a write cache for improved performance and data efficiency. Though unlikely to happen in most cases, the data cached in the volatile DRAM might be potentially affected if a sudden power loss takes place before the cached data is flushed into non-volatile NAND flash memory.

3.5 ATA Secure Erase

ATA Secure Erase is an ATA disk purging command currently embedded in most of the storage drives. Defined in ATA specifications, (ATA) Secure Erase is part of Security Feature Set that allows storage drives to erase all user data areas. The erase process usually runs on the firmware level as most of the ATA-based storage media currently in the market are built-in with this command. ATA Secure Erase can securely wipe out the user data in the drive and protects it from malicious attack.

3.6 TRIM

TRIM is a SATA command that helps improve the read/write performance and efficiency of solid-state drives (SSD). The command enables the host operating system to inform SSD controller which blocks contain invalid data, mostly because of the erase commands from host. The invalid will be discarded permanently and the SSD will retain more space for itself.

4. Reliability Specifications

4.1 Environments

Table 4-1 SFD25H-M environmental specifications

Environment	Specification
Temperature	0°C to 70°C (Operating)
	-40°C to 85°C (extended)
	-40°C to 85°C (in storage)
Humidity	RH 90% under 40°C (in Operation)

Note:

- Shock and Vibration specifications are subject to change without notice.
- Extended operating temperature is ONLY available in 512GB model.

4.2 Mean Time Between Failures (MTBF)

Mean Time Between Failures (MTBF) is predicted based on reliability data for the individual components in SFD drive. The prediction result for SFD25H-M is more than 1,000,000 hours.

Notes about the MTBF: The MTBF is predicated and calculated based on "Telcordia Technologies Special Report, SR-332, Issue 2" method.

4.3 Certification and Compliance

- CE
- FCC
- RoHS

5. Electrical Characteristics

5.1 Operating Voltage

Table 5-1 lists the supply voltage for SFD25H-M.

Table 5-1 SFD25H-M operating voltage

Parameter	Conditions
Supply voltage	5V \pm 5%

5.2 Power Consumption

Table 5-2 lists SFD25H-M power consumption.

Table 5-2 SFD25H-M power consumption

Performance	Capacity	
	512 GB	1 TB
Active Mode (mA)	1,180	1,410
Standby Mode (mA)	60	60

Note: power consumption may vary depending on flash configurations or platforms..

6. Mechanical Specifications

6.1 Dimensions – 7mm Housing

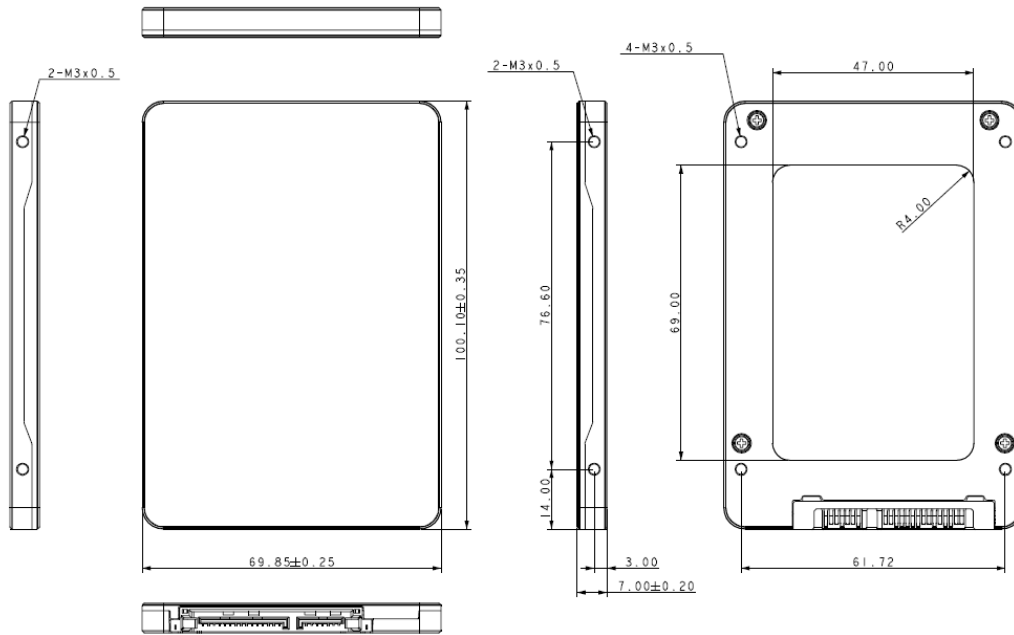

Unit: mm
Tolerance: ± 0.2

6.2 Dimensions – 9.5mm Housing

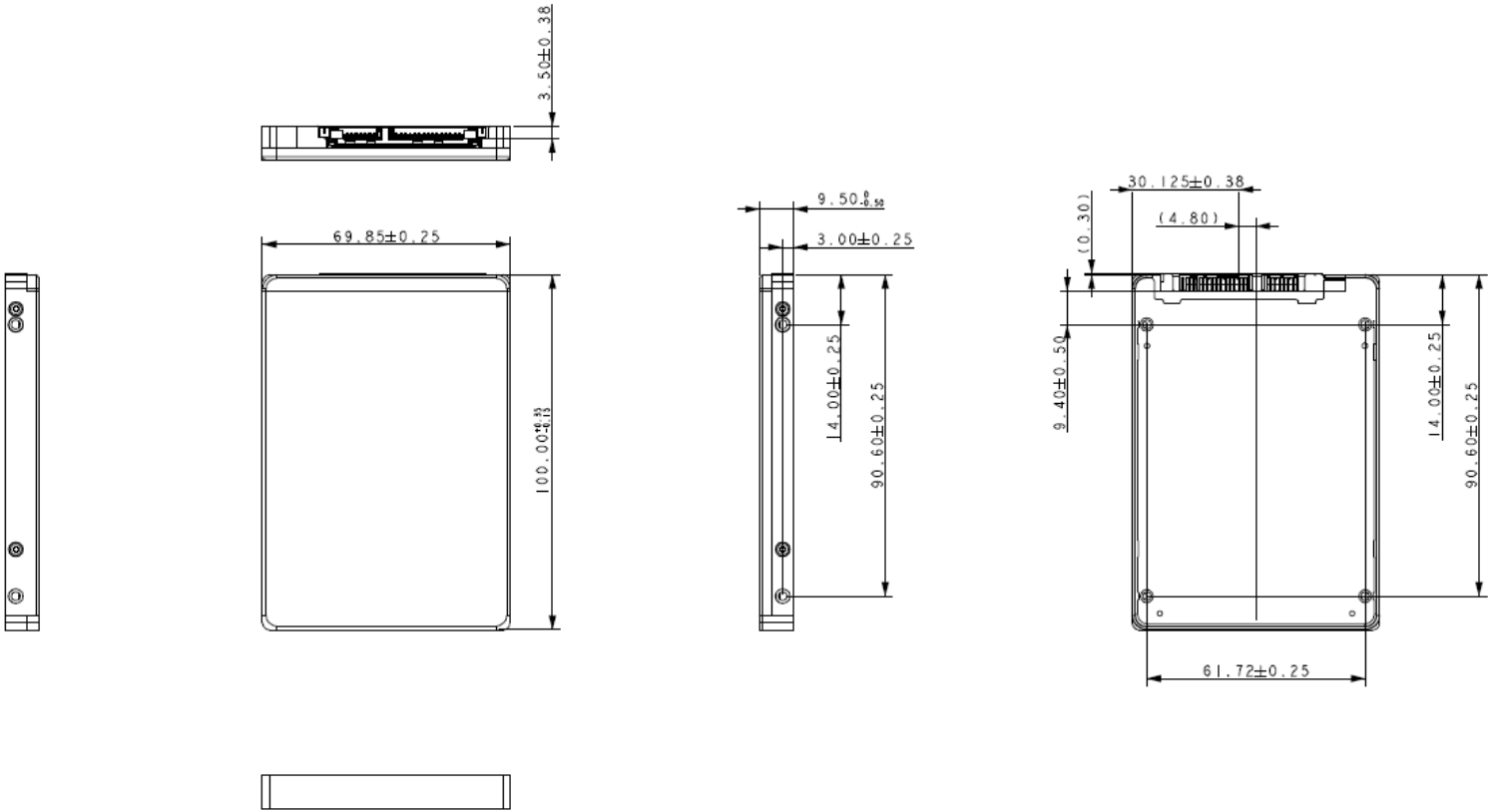

Unit: mm
 Tolerance: ± 0.2

7. Product Ordering Information

7.1 Product Code Designations

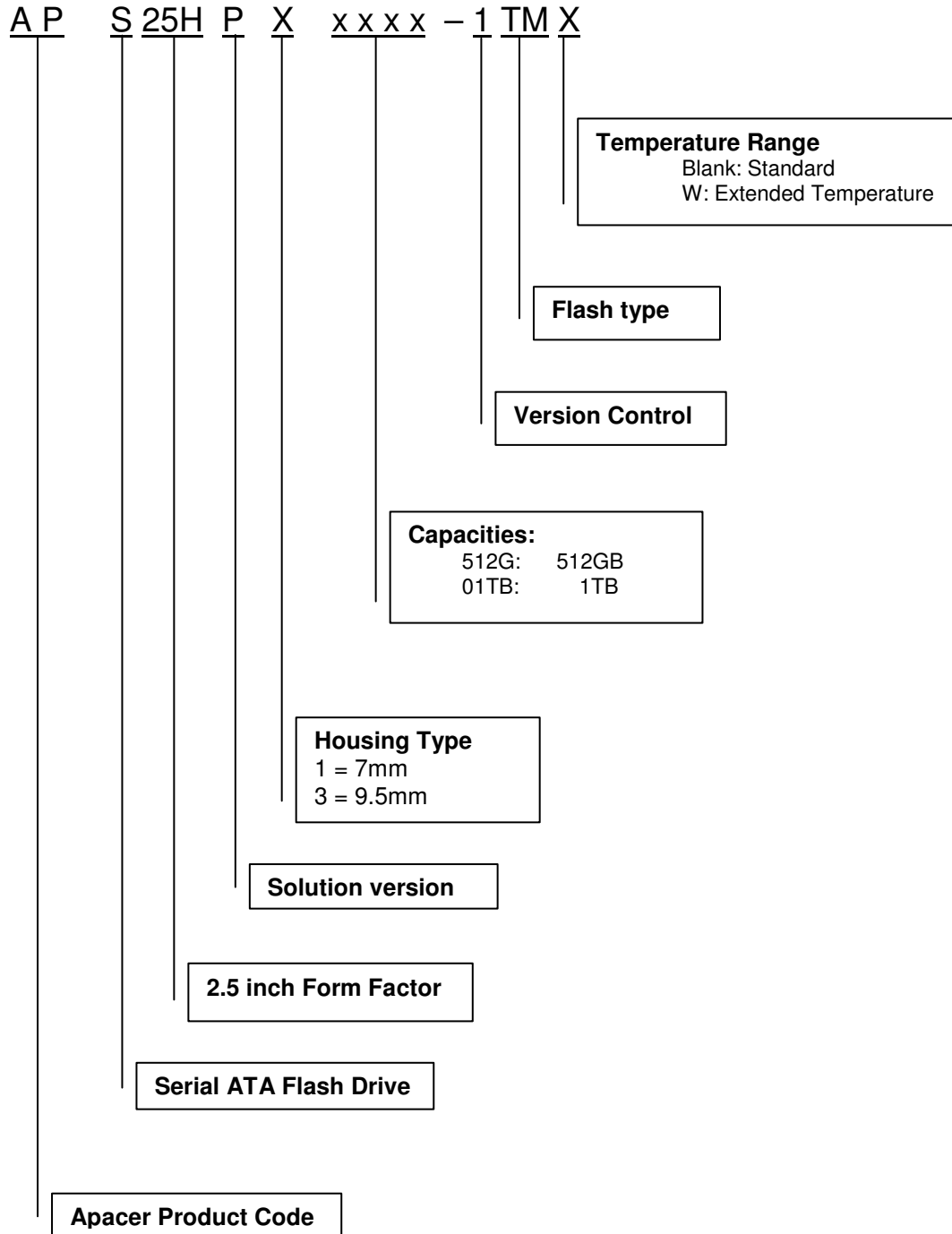

7.2 Valid Combinations

7 mm Housing

Capacity	Standard	Extended Temperature
512 GB	APS25HP1512G-1TM	APS25HP1512G-1TMW
1TB	APS25HP101TB-1TM	--

9.5 mm Housing

Capacity	Standard	Extended Temperature
512 GB	APS25HP3512G-1TM	APS25HP3512G-1TMW
1TB	APS25HP301TB-1TM	--

Note: Please consult with Apacer sales representatives for availabilities.

Revision History

Revision	Description	Date
0.1	Preliminary	10/15/2013
0.2	Updated the LBA and total bytes	10/16/2013
1.0	Official release	12/10/2013
1.1	Added extended operating temperature feature for 512GB model	01/15/2014
1.2	Added 9.5mm housing	06/11/2014

Global Presence

Taiwan (Headquarters)	Apacer Technology Inc. 1F., No.32, Zhongcheng Rd., Tucheng Dist., New Taipei City 236, Taiwan R.O.C. Tel: 886-2-2267-8000 Fax: 886-2-2267-2261 amtsales@apacer.com
U.S.A.	Apacer Memory America, Inc. 386 Fairview Way, Suite102, Milpitas, CA 95035 Tel: 1-408-518-8699 Fax: 1-408-935-9611 sa@apacerus.com
Japan	Apacer Technology Corp. 5F, Matsura Bldg., Shiba, Minato-Ku Tokyo, 105-0014, Japan Tel: 81-3-5419-2668 Fax: 81-3-5419-0018 jpservices@apacer.com
Europe	Apacer Technology B.V. Science Park Eindhoven 5051 5692 EB Son, The Netherlands Tel: 31-40-267-0000 Fax: 31-40-267-0000#6199 sales@apacer.nl
China	Apacer Electronic (Shanghai) Co., Ltd 1301, No.251,Xiaomuqiao Road, Shanghai, 200032, China Tel: 86-21-5529-0222 Fax: 86-21-5206-6939 sales@apacer.com.cn
India	Apacer Technologies Pvt Ltd, # 535, 1st Floor, 8th cross, JP Nagar 3rd Phase, Bangalore – 560078, India Tel: 91-80-4152-9061 sales_india@apacer.com